

# R238™ *Premium All-Position Radial*

Designed for Regional Pickup and Delivery Service

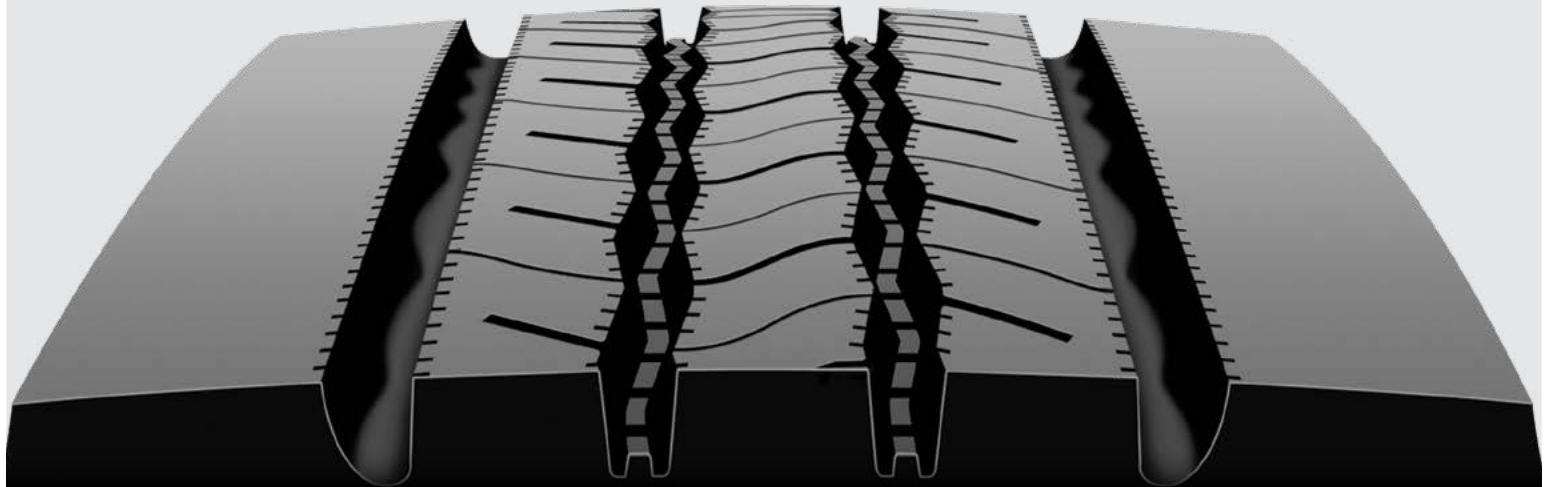

**Scrub Resistance ■ Long Wear Life ■ Durable**



## Precisely the Right Tire

The Bridgestone R238 is an all-position radial tire that stands up to the harshness of severe, high scrub environments in regional pickup and delivery applications. Protective features in the casing and tread design help resist damage from curbing and maneuvering scrub, contributing to long tread life. The pattern complements the Bridgestone R268 Ecopia all-position tire, which is available in larger sizes.

## R238 Features

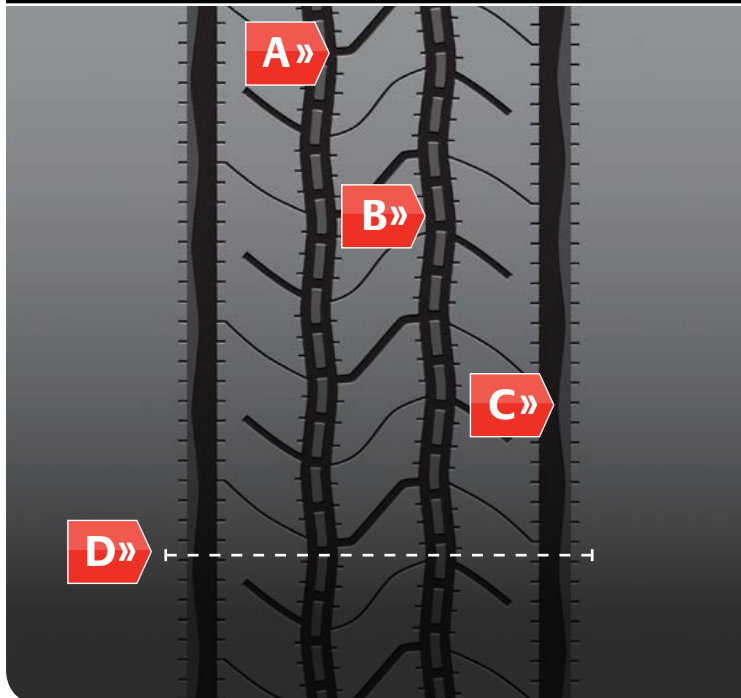

- A** **Special Groove Shape**  
.....  
Designed for improved rib tearing resistance.
- B** **Stone Rejector Platforms**  
.....  
Help provide resistance to stone drilling in two center grooves to protect belts and enhance casing durability.
- C** **Waved Channel Design**  
.....  
A wavy design in the channel reduces groove bottom strain, combating the initiation and spread of irregular wear.
- D** **Optimized Rib Distribution**  
.....  
Ribs are uniquely proportioned for added stiffness, which helps reduce irregular wear throughout the footprint.

## R238 Features

### High Scrub Tread Compound

Enhances resistance to tread scrubbing, leading to increased tread life.

### NanoPro-Tech™ Compound

Patented NanoPro-Tech polymer technology limits energy loss for improved rolling resistance.

### Wide, Solid Shoulder Ribs

Help deliver enhanced resistance to maneuvering scrub and increased tread life.

### Wider Belts

Wide belts extend to the shoulder area, which helps to reduce the occurrence of both irregular shoulder wear and casing damage.

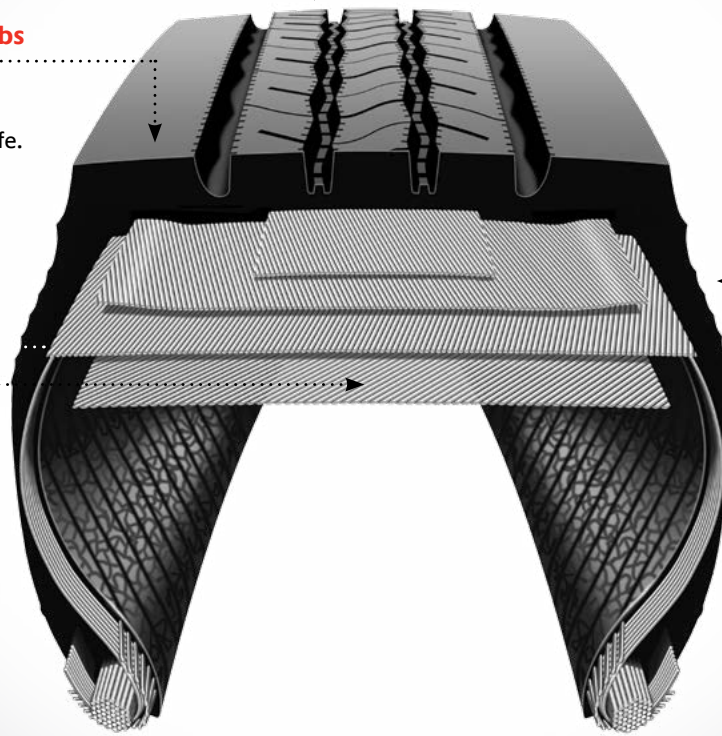

### Sidewall Protector Ribs

Preserve casing durability by fighting curbing damage with thick ribs on both sidewalls.

R238 TIRE SIZE	Load Range	Article Number	Weight [lbs/kg]	Meas. Rim [in]	Overall Diameter [in/mm]	Overall Width [in/mm]	Static Loaded Radius [in/mm]	Overall Width Loaded [in/mm]	Revs [per mile/km]	Tread Depth [32"/mm]	Max Load Capacity		Inflation Pressure [PSI/kPa]	Max Speed [mph/kph]
											Single [lbs/kg]	Dual [lbs/kg]		
215/75R17.5 metric	G	000283	66 30	6.00 --	30.7 780	8.8 224	14.4 364	9.7 246	677 421	15 12	3750 1700	3525 1600	100 690	75 120
215/75R17.5 metric	H	003887	66 30	6.00 --	30.7 780	8.8 224	14.4 364	9.7 246	677 421	15 12	4805 2180	4540 2060	125 860	68 110
245/70R17.5 metric	J	004085	74 34	7.50 --	31.4 798	9.6 244	14.5 368	10.6 269	662 411	17 13	6005 2725	5675 2575	125 860	68 110
225/70R19.5 metric	F	248664	66 30	6.00 --	32.2 818	8.7 221	15.0 381	9.5 242	644 400	16 13	3640 1650	3415 1550	95 660	75 120
225/70R19.5 metric	G	248681	66 30	6.00 --	32.2 818	8.7 221	15.0 381	9.5 242	644 400	16 13	3970 1800	3750 1700	110 760	75 120
245/70R19.5 metric	F	248732	82 37	6.75 --	33.3 846	9.3 236	15.5 393	10.3 261	623 387	18 14	4080 1850	3860 1750	95 660	75 120
245/70R19.5 metric	G	248698	82 37	6.75 --	33.3 846	9.3 236	15.5 393	10.3 261	623 387	18 14	4540 2060	4300 1950	110 760	75 120
245/70R19.5 metric	H	248715	82 37	6.75 --	33.3 846	9.3 236	15.5 393	10.3 261	623 387	18 14	4940 2240	4675 2120	120 825	75 120
265/70R19.5 metric	G	000279	84 38	7.50 --	34.1 866	10.0 254	15.8 401	11.0 268	609 378	17 13	5510 2500	5205 2360	110 760	75 120

Warranty information is available at [bridgestonetrucktires.com](http://bridgestonetrucktires.com) or from your Bridgestone representative, dealer or truck stop.

**Bridgestone Casings & Bandag Retreads: State-of-the-Art Smart.** Pairing your Bridgestone casing with a Bandag retread extends the life of your tires and keeps your money where it belongs — with you. With specialized tread patterns that stand up to your operation's demands, plus cutting-edge compounds that resist wear and tear, Bandag retreads perform like new tires at a fraction of the cost. For more information, visit [bandag.com](http://bandag.com).

**Prove it to yourself.** Run the only test that really matters: Try the R238 on your trucks, on your routes and with your drivers — in short, in your world. See for yourself how the R238 can cut your cost per mile. Call your Bridgestone representative today!

**BRIDGESTONE**